

# Automated Lawn Mower Robot using IoT

**Dr. Madhavi Waghmare**

Information Technology  
VCET (Mumbai University)  
Vasai, India

Pritish Mair

Computer Engg.  
VCET (Mumbai University)  
Vasai, India

Soham Waghmare

Computer Engg.  
VCET (of Affiliation)  
Vasai, India

Sharvin Dedhia

Computer Engg.  
VCET (Mumbai University)  
Vasai, India

**Abstract**—The importance of lawn care simply cannot be ignored, as your lawn is a contributing factor to the beauty of your house. It needs care on regular basis. This project summarizes and reviews different technological developments for making efficient and cost-effective lawn mowers. A lawn mower is a device which is used to mow/ cut i.e. cut the grass of a lawn to an even height. It can be operated manually or by some energy conversions such as solar power battery power etc. Generally, these are powered by electric motor or internal combustion engine and dc motors. In this project, effort has been made to modify the old mower to improve its usability. The overall geometry is made smaller and lighter. Adjustable cutting motor height is introduced for better mowing of grass at intricate locations.

**Keywords**—Robot, Automation, IoT, Arduino UNO

## I. INTRODUCTION

This template, modified in MS Word 2007 and saved as a “Word 97-2003 Document” for the PC, provides authors with most of the formatting specifications needed for preparing electronic versions of their papers. All standard paper components have been specified for three reasons: (1) ease of use when formatting individual papers, (2) automatic compliance to electronic requirements that facilitate the concurrent or later production of electronic products, and (3) conformity of style throughout a conference proceedings. Margins, column widths, line spacing, and type styles are built-in; examples of the type styles are provided throughout this document and are identified in italic type, within parentheses, following the example. Some components, such as multi-leveled equations, graphics, and tables are not prescribed, although the various table text styles are provided. The formatter will need to create these components, incorporating the applicable criteria that follow[1].

Lawn care and maintenance is a tedious thing to do for people who are always busy in daily life. Because it's not just about cutting the grass, it also includes services to receive the necessary nutrients to achieve its thickness, colour and overall health benefits. There are many things that are harmful to your lawn. for example, high temperature, draught, weeds, insects etc. Why does a lawn need a good care and maintenance? There are several reasons[2]. It helps prevent lawn diseases. Every season, problems like brown patch disease pose a threat to the health and stability of your lawn. Also it adds to your homes curb appeal. It contributes

to healthy grass for family and pets to play in, its good for the environment and It helps control pests and weeds. A lawn mower is a device that helps to mow or cut the grass at desired height. Mowing the lawn with a standard motor powered lawn mower is an inconvenience, and no one takes pleasure in it[3]. Cutting grass cannot be easily accomplished by elderly, younger, or disabled people. Motor powered push lawn mowers and riding lawn mowers create noise pollution due to the loud engine, and local air pollution due to the combustion in the engine. Also, a motor powered engine requires periodic maintenance such as changing the engine oil. Even though electric lawn mowers are environmentally friendly, they too can be an inconvenience. Along with motor powered lawn mowers, electric lawn mowers are also hazardous and cannot be easily used by all. Also, if the electric lawn mower is corded, mowing could prove to be problematic and dangerous. We tried to provide solution to overcome these problems. Due to rapid development in the present information and communication systems, robots are designed to be widely used in small and large scale in every area of daily life and industries. They are employed to reduce human dependencies in performing a task and to reduce time for production while maintaining consistent quality of production outputs. Robotic devices are widely used in manufacturing industries, advance surveillance systems and for domestic use as well[4]. Modern houses include a compound often used as garden with grass which grows and need to be maintained at a short height. Conventional lawn mowing is often a hassle and time consuming in cutting the grass. The task of manual lawn mowing can be replaced by automatic lawn mower using a robot programmed to perform such task. A robotic lawn mower is designed and installed in this project. The objective of the electric remote control lawn mower is to extend the design of currently used lawn mowers, and to improve the capabilities of standard robotic lawn mowers as well as assuring cost efficiency. It is safe to use, as well as efficient because it electric powered and cordless. With these objectives mentioned, the electric robotic lawn mower is environmentally friendly.

## II. EXISTING SYSTEM

We have always wanted to serve the people of this world. The motivation for this device came from watching surrounding people doing difficult household chores on their

own, putting so much efforts on some works, especially old and disabled people[5]. To minimize their efforts we thought of combining available devices or machines with IOT(internet of things). IOT is a platform which gives us opportunity to change working way of a system by taking all the controls in our hands. A technology which is being used in many of the today's applications and use of which is increasing rapidly on daily basis. In this technology many embedded systems, different sensors work together and interact with each other using internet and information exchange is done through a wireless network. Many problems are solved using IOT technology such as home automation which minimize the wastage of resources as well as minimize the risk of many accidents, sometimes car doors are open while driving, seat belt is locked in a plane which could result in accident are also being avoided. Major advantage of IOT technology is it provides real time solutions for the given problems. So we used current lawn mower system and made it user friendly by making it fully controllable and easy to use so user

### III. PROBLEM STATEMENT

The current situation we face about lawn maintenance is that we have to put lots of efforts to it. We need to keep track of days on which grass is to be mowed. We must go there and cut the grass on our own. Also the available lawn mowers are not user friendly as well as environment friendly as it emits CO<sub>2</sub> and carbon monoxide and some mowers create noise pollution. This project provides the solution for it. The project is based on arduino UNO and a mobile application to control the robot. The main focus for this project is to remove the chore of mowing your lawn. By creating a lawn mower that handles this task autonomously, the user is freed from this physically demanding and time consuming task.

Keep your text and graphic files separate until after the text has been formatted and styled. Do not use hard tabs, and limit use of hard returns to only one return at the end of a paragraph. Do not add any kind of pagination anywhere in the paper. Do not number text heads-the template will do that for you.

#### A. Limitations

We have always wanted to serve the people of this world. The motivation for this device came from watching surrounding people doing difficult household chores on their own, putting so much efforts on some works, especially old and disabled people.

#### B. Scope

To minimize their efforts we thought of combining available devices or machines with IOT(internet of things). IOT is a platform which gives us opportunity to change working way of a system by taking all the controls in our hands. A technology which is being used in many of the today's applications and use of which is increasing rapidly on daily basis. In this technology many embedded systems, different sensors work together and interact with each other using internet and information exchange is done through a wireless network. Many problems are solved using IOT technology such as home automation which minimize the wastage of resources as well as minimize the risk of many accidents, sometimes car doors are open while driving, seat belt is locked in a plane which could result in accident are

also being avoided. Major advantage of IOT technology is it provides real time solutions for the given problems. Hence we used current lawn mower system and made it user friendly by making it fully controllable and easy to use so user don't have to put much efforts in it.

#### C. Review of literature

The first lawn mower was contrived in 1827 and patented in 1830 by Edwin Beard Budding, an engineer from Stroud, Gloucestershire, England. He got this idea after seeing a machine in a textile industry, they used a cutting cylinder (or bladed reel) mounted on a bench to trim cloth to make a smooth finish after weaving. Budding realized that a similar concept would enable the cutting of grass if the mechanism could be mounted in a wheeled frame to make the blades rotate close to the lawn's surface.

First lawn mower was all made of cast iron and featured a large rear roller with a cutting cylinder (reel) in the front. Cast iron gear wheels transmitted power from the rear roller to the cutting cylinder. These machines were remarkably similar to modern mowers. By 2000, robotic are most important[6] things in the future, no matter if they are used to work in industry or at our homes, mimic some of the human capabilities, or used to access dangerous environments, launched to space, or simply used to play with[7].

They are helping to reduce human dependencies in performing a task and to reduce time for production while maintaining consistent quality of production outputs. Robotic devices are commonly used in manufacturing industries and for domestic use as well[8].

Modern houses normally garden with grass need to be maintained at a short height, is most user upset. Traditional lawn mowing is often a trouble, dangerous and time consuming in cutting the grass. The task of manual lawn mowing can be replaced by automatic lawn mower using a robot programmed

to perform such task[9].

An automatic lawn mower is designed and installed in this project. Automatic Lawn mower also can act as an aid to homeowners who can no longer perform physically demanding tasks, such as the elderly or disabled. On the residential side, many elderly and disabled enjoy lawn maintenance, but are no longer able to enjoy the satisfaction of maintaining their own lawn due to the physical demands of traditional lawn mowing equipment[10].

These researches (automatic lawn mowers) are very elderly and disabled friendly with the simple. Automatic lawn mower also has the Perfect Balance Between Eco-friendly and Practicality. Robots are very expensive, not any people really want to buy costly robotic devices. Create a low cost inexpensive automatic lawn mower will allow house owners to maintain their lawn without spending much time and money. An autonomous robot can mow the lawn of a given species area of the garden without any human supervision[11].

### IV. WORKING

We have to integrate all the modules in arduino UNO and then add other features like object detection, detecting grass boundaries etc. Also, proper blades for cutting grass in right manner are needed. Real time testing with all possible inputs

to make our device more accurate and more feasible with real time users. And also modify the robot and add more features In first phase we studied all the hardware components required for the project[12]. After we learned the working mechanism of traditional lawn mower. So we assembled hardware components accordingly. In second phase, Interfacing has to be done between microcontroller and hardware module. This was the harder phase than phase one because interfacing between hardware and microcontroller is a bit difficult. In third and final phase , App development was necessary. so we did some study

about it. There are plenty of online applications available on internet which are specially designed to control arduino, wifi module, bluetooth module etc[13].

*A. Design of Lawn Mover*

We chose the Blynk application which is used most when there is need of controlling arduino and other modules[14]. We also performed detailed analysis to estimate the speed of the blade and whether it is sufficient to perform the intended job. After design and development of the lawn mower, it is tested on four different species of grass. We tried to develop a height adjustable mechanism for the cutting blade.

*B. Methodology*

The methodology of proposed system is presented below:

- Study of existing system
- Modelling of our design
- Study the requirements of the project
- Requirement gathering
- Working on hardware design
- Arduino interfacing with hardware components
- Working on software application
- Arduino and wifi module interfacing with software(application)

*C. System Design*

Proposed system was designed with the goal to create a product that could allow someone to operate it without directly pushing it, but rather by controlling it remotely. In keeping with the motivation behind the project, the goal of our design is to reduce end user work through the utilization of an easy-to-use device. Our project improves on existing consumer products by removing the need to bury insulated wires to identify the boundaries of the lawn. This complies with our motivation to reduce work by eliminating this tedious, initial setup. In addition to ease of use through automation, our goal is to create a project that is accurate and efficient. Safety is another factor that will be considered for our project. Implementation of obstacle avoidance is a primary objective for the safety of our project. Through the use of ultrasonic sensors, the mower will discern the location of obstacles present within the cutting area. Main components used in design.

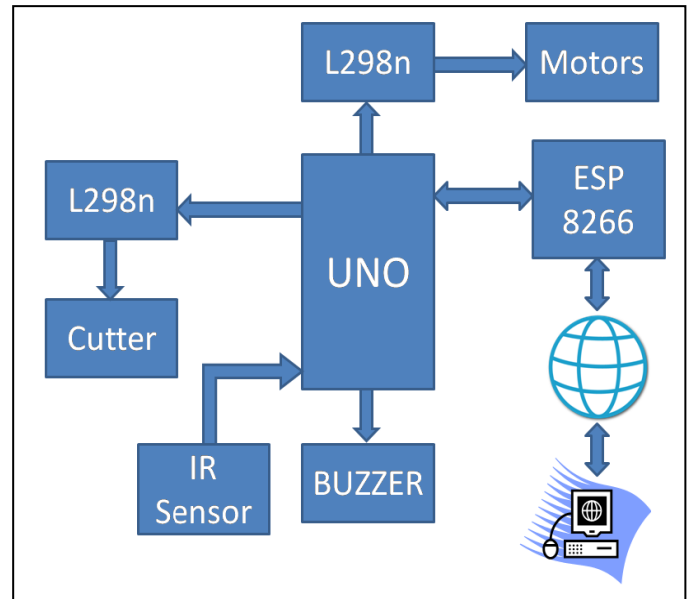

Fig. 1. Block diagram of Lawn Mower.

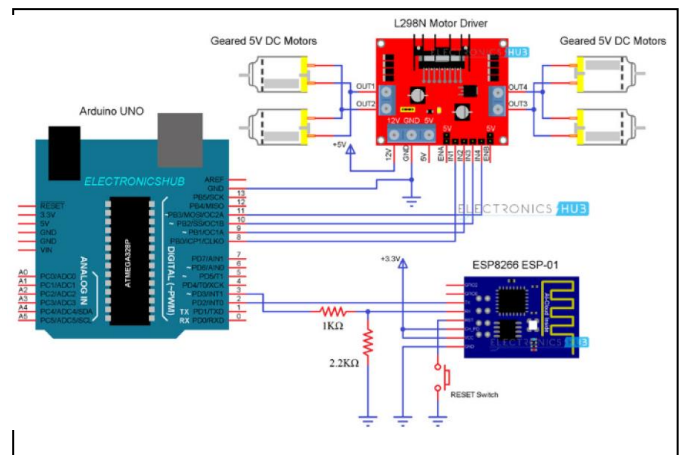

Fig. 2. Circuit diagram of Lawn Mower.

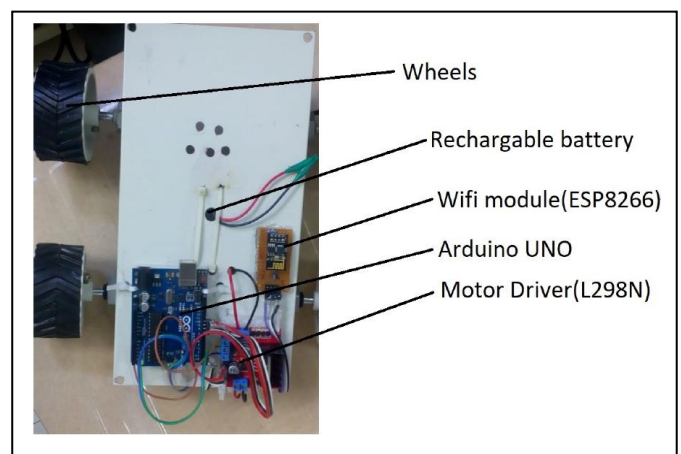

Fig. 3. Circuitry of Lawn Mower



Fig. 4. Working Model of Lawn Mower (Final Output)

D. Result Analysis

Fig. 3, In designing the cutting blade, the force required to cut the lawn as well as the force acting on the blade was considered. The force required by any sharp object to have impact on the grass is less than 10 Newton. It is also dependent on the height, density and the area covered by the object.

Therefore, in designing the blade of the solar powered lawn mower, the force required for effective mowing should be greater than 10 Newton. A stainless steel is used in the construction of the cutting blade because of its strength and weight which can transmit same speed as that of the DC motor or a little less cause of friction.

**Testing and Results:** To check feasibility of the prototype , we tested it on different type of grass. for example, spare grass, elephant grass, stubborn grass. Also we examine its performance on different grounds which have different slope.

- The area of cut(battery duration) depends on lawn conditions, grass density, moisture content, grass length and height of cut
- Switching the product on and off frequently during cutting will also reduce the area of cut.
- To improve the rea of cut , it is recommended to cut more frequently, raise the cutting height.
- The maximum cutting height is 3 inches.
- The run time is 45 minutes(fully charged battery)

PARAMETER	TRADITIONAL LAWN MOWER	AUTOMATED LAWN MOWER
Pollution	Causes more pollution	Clean and pollution free
Effort	More	Less
Maintenance required	More	Less
Remote control	Not available	Available
Noise	More	Less
Efficiency	Less	more

Table1. Comparative study

V. CONCLUSION

The objective in this project was to design an Android controlled lawnmower. The design used a simple interface

between an Android platform, a WiFi module, an Arduino Uno, and an H-Bridge. In this interface, the Android device connected to the WiFi module . This allowed input signals from the Android device to be read by the Arduino which could be translated directional control through differential steering. There were a number of improvements that could have been made in order to improve the design.

A software side improvement to this project would be to develop a method of streaming the video from the wireless camera onto the Android application. This would work by having the camera stream the video onto a website containing a live stream. The application could then link to the stream, allowing the video to appear on the Android application.

This project proved to be a challenging yet rewarding experience. Through this project, it was proven that it is possible to use an Android device to automate complicated tasks that can normally be physically demanding, or otherwise impossible. While this design would need refining before being mass produced, it is possible that a similar design to make mowing ones lawn a much more relaxing task.

REFERENCES

- [1] Aponte-Roa, Collazo, X., Goenaga, M.Espinoza, A. A. Vazquez, K. , "Development and Evaluation of a Remote Controlled Electric Lawn Mover," IEEE 9<sup>th</sup> Annual Comuting and Communication Workshop and Conference, 2019 (CCWC)
- [2] Uo-Shing Huang, Hsiung-Cheng Lin, Keng-Chih Lin, Shih-Hung Kao, "Intelligent Auto saving energy Robotics Lawn Mower" Man and Cybernetics System IEEE international Conference, 2010.
- [3] Wasif, "Design and Implementation of Autonomus Lawn Mower Robot controller ," 7<sup>th</sup> International Conference on Emerging Technology 2011.
- [4] Taj Mohammad Baloch and Timothy Thien Ching Kae, "Design and Modelling a Prototype of a Robotic Lawn Mower," Electrical and Electronic Engineering Department Universiti Teknologi PETRONAS 31750 Bandar Seri Iskandar, Perak
- [5] Huiwen Guo, Xinyu Wu, Jianquan Sun, Yongsheng Ouand Wei Feng, BR. Nicole, "Robust Grass Boundary Detection For Lawn Mowerwith Novel Design of Detection Device".
- [6] Alessio Levratti, Cristian Secchi, Cesare Fantuzzi,"A Low Cost Localization Algorithm For An Autonomus Lawn Mower," IEEE International Workshop on Robot Motion and Control, 9<sup>th</sup> Annual Conf. Poland2013.
- [7] Haydar Sahin ; Levent Guvenc, "Household robotics: autonomous devices for vacuuming and lawn mowing" IEEE Control Systems Magazine ( Volume: 27 , Issue: 2 , April 2007 )
- [8] Sivaguru J, Anush P "Infra Red Assisted Navigation for Automatic Lawn Mower Robot" International Journal of Recent Technology and Engineering (IJRTE) ISSN: 2277-3878, Volume-8, Issue-2S11, September 2019
- [9] Kiran A. Shende, Mamta A. Shapamohan, Kalpana V. Tale3, U. S. Raut, "Auto Saving Energy Robot Mower with MultiSensor Fusion Navigation" International Journal of Research in Engineering, Science and Management Volume-2, Issue-1, January-2019.www.ijresm.com | ISSN (Online): 2581-5792
- [10] S.X. Yang, C. Luo, "A neural network approach to complete coverage path planning" IEEE Transactions on Systems, Man, and Cybernetics, Part B (Cybernetics) ( Volume: 34 , Issue: 1 , Feb. 2004 )
- [11] AlessioLevratti, MatteoBonaiuti, CristianSecchi ,CesareFantuzzi, "An Inertial/RFID Based Localization Method for Autonomus Lawnmowers" Elsevier IFAC Proceedings Volumes Volume 45, Issue 22, 2012, Pages 145-150.
- [12] <http://circuitdigest.com/microcontroller-projects/arduino-wificontrolled-robot>
- [13] <https://www.instructables.com/id/DIY-WIFI-RC-Car-With-ESP8266-and-Arduino-IDE/>
- [14] <https://www.hackster.io>