

Multi Shape Floor Cleaner

Prof. Prafulla Patil

Dept. Instrumentation

Vidyaaridhini Collage of Engineering and Technology

Joshua Mascarenhas

Dept. Instrumentation

Vidyaaridhini Collage of Engineering and Technology

Vasai, India

Saurabh Ghadi

Dept. Instrumentation

Vidyaaridhini Collage of Engineering and Technology

Vasai, India

Prajas Kondlekar

Dept. Instrumentation

Vidyaaridhini Collage of Engineering and Technology

Vasai, India

Jayesh Sankhe

Dept. Instrumentation

Vidyaaridhini Collage of Engineering and Technology

Vasai, India

Abstract- The cleaning of floors in commercial and residential building involves repetitive and boring task. For this reason, many autonomous robots have been developed in recent decades. Many of these are having circular or D shape. For any given cleaning environment, the presence obstacles are inevitable. These obstacles create gaps that are difficult for traditionally available cleaner to reach. One solution is to make smaller sized cleaners. However, this would greatly reduce the cleaning time. For this reason, we can clearer that can transform its shape corresponding to the cleaning environment. There are many types of shape changing cleaning bots developed, overall these cleaner robots have many shapes but each of these shapes provides small advantage over the other. Our cleaner is one of a kind robot that can transform its shape from rectangle to triangle and then parallelogram with slimmest width as compared to other shapes. The other objective our project tries to offer is to generate a robust navigation method using cheap ultrasonic sensor rather than lidar

Keywords- reconfigurable robot, area coverage; multi-shape, tilling ,navigation,floor cleaning and hinged dissection.

I. INTRODUCTION

Since the invention of vacuum cleaner, these vacuume cleaners had to be operated with the guidance fo human hands throughout the room, there has been improvements in the mechanical design over the next century. During 1990s and the 2000s a lot of progress is made in AI based self-navigation cleaning. which includes. many applications such as lawnmower, painting and other cleaning application. Which use similar navigation technics, these research efforts have resulted in the emergence of robotic cleaning devices that have significantly improved people's quality of life and their overall productivity. The firms that currently dominate the market are iRobot, Samsung, Neato, and Dyson. The robotic floor cleaning products that are produced by these organizations typically take the form of a circular or D-shaped device that can autonomously navigate a given area through the use of integrated sensors. A large amount of robotics literature has evaluated the design, mechanism, function, autonomy,benchmarking, and human-robot interaction aspects of a range of cleaning robots.[4]

Recently there also been many researches in multi-shape robot Such as h-tetro, hTeatrakis, three block shape and hexagon shape These robots can take many shapes, however some shape have little advantage over the other. H-Tetrakis [1] also offer good solution for sharp comers, but all the shapes this robot provides is similar to each other thus adding small benefit due to change in shape The Project has three subsystems: electrical, software and mechanical of which microcontroller, sensor and motor are the electronic electrical and mechanical subsystem respectively A cleaning robot uses a sensor to detect the obstacles and the microcontroller manipulates its direction as per the inputs. It is programmed to accept input to sense obstacles around it and control the robot to avoid any collisions and find path to cover the entire floor. In case of an obstacle, or a potential collision, the microcontroller controls the wheel of the robot by a motor driver. The shape is change using hinged dissection

II. PROBLEM STATEMENT

The target of any robot is to maximise clearing coverage area and increases clean time rate. Cleaning of large floor using traditional available robot cleaner has limited coverage area and time consumption is more in some cases. One major factor that contributes to their performance deficit is their fixed morphology design, which highly constrains their navigation and access. The introduction of self-reconfigurable or multi-shape floor cleaner can overcome this aspect. As the name implies multi-shape means it changes shapes according to the space available at the surroundings. It works on navigation algorithm that maps the environment and follows the path to cover floor area and navigate obstacle by using sensors. Another problem is same area is cleaned many times, for this proper path is be to be decided.

III. PROJECT COMPONENTS

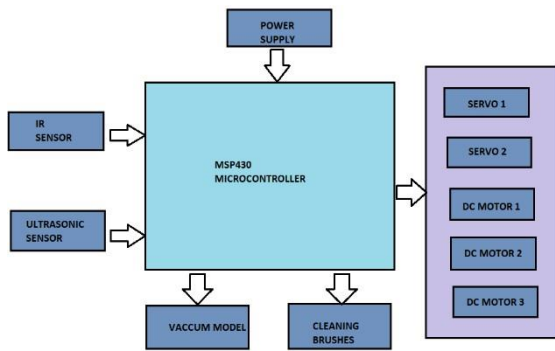

Fig 1 Block diagram of project

A. Ultrasonic sensor

Ultrasonic is the main sensor used for navigation. It is placed on the axis of servo motor. By this rotation, the angle and the distance from the obstacles are measured, it creates a map of the cleaning area. The map can be displayed on a processing tool on a computer. This sensor works by emitting sound waves at a frequency too high for humans to hear. The sound reflected back from obstacles and received into by the sensor receiver. Calculating distance based on the time required to travel.

B. IR sensor

IR Sensor, that emits infrared light in order to sense the presence of an object if it is near by. An IR can also measure distance from an object from close range as well as detects the motion. These sensors are connected to the microcontroller. The microcontroller gives the signal to the motor for control of location, shape shifting and cleaning.

C. Servo motor

A servo motor is attached to the two hinges of the robot. Servo motor is a rotary actuator or a motor that allows for a precise control in terms of the angular position, acceleration, and velocity. MG995 servo motor is used with 12Kg-cm at 6.6V, which is enough to move the hinged part to the other side during shape transformation and lock the hinge in position.

D. Vacuum module

The vacuum module sucks air from the bottom of the cleaner and collects the dirt in the dust bag. Rest of the air is blown out. The vacuum module is located at the central shape. Whereas the rest of the shapes has brushes to push the dirt toward the central vacuum module.

d. Other Components

An encoder DC motor is used to find out the current relative position or speed of the motor. Two phase hall effect encoders are used. Power supply: Containing DC rechargeable battery of 7.4V LIPO battery 1000Amph. Motor drivers act as an interface between the motors and the control circuits. As motor require high

amount of current whereas the controller circuit works on low current signals. MSP430F529LP Microcontroller.

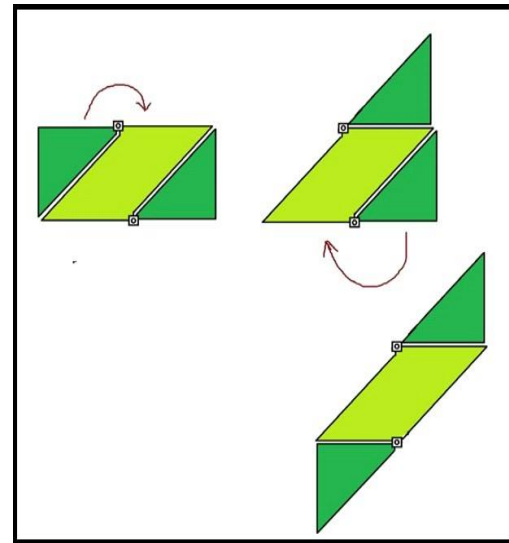

Fig 2. Shape transformation phases

IV. SHAPE TRANSFORMATION

There are three modules of clearer, the centre is the shape of parallelogram and two isosceles right-angle triangles connected with hinges. There are two hinges at the two wider corners of the parallelogram, each hinge is attached to a right-angle triangle at one of its sharp corners. There are three omni wheels present under the central module for locomotion of the robot.

Total four shapes can be created, out of which two shapes are mirror images. Thus, there are three useful shapes that can be created as given in the figure. The first shape is a rectangle that can be converted to a triangle shape by moving the upper triangle on top of the main module. A longer, thinner parallelogram can be created by moving the lower triangle below the central parallelogram. The rectangular shape can be used in areas where obstacles are not present. Other shapes that are long may not be able to move comfortably across small areas. The triangular shape transformation is the shape that can provide clearing for corners of the room. With a long structure, it is useful to cross long thinning gaps in a room.

V. THREE OMNI WHEELS DRIVE



Fig 3. Omni Wheel

Omni wheels are used to allow for free movement at right angles, as well as for driving movement in forward and backward directions. Three omni wheels are used for

stable movement and cancel out torque, by giving each motor a specific amount of speed the robot can move in any direction and speed.

The motor uses pwm signal (Pulse With modulation)The digital signals duty cycle is changed to to change average voltage given to driver.The pwm is given to the motor driver. A digital PID control is used which based on position control, which can be modified to speed by giving ramp input to the set point of the pid controller. The PID calculates the value of voltage to be given to the motor by comparing the encoder value with setpoint.[5]

A Kinematic model:

Fig 4 shows the schematic view of three wheeled omnidirectional robot, where each wheel are (W1, W2, W3) 10cm apart, “R” is the length from robot centre mass to each wheels. VW1, VW2, VW3 are linear velocities of wheel. 1, 2 and 3. ‘r’ is the radius of each omnidirectional wheels. From the kinematics equation all forces are divided into two components vertically ‘Y’ axis ‘sin’ component and horizontal ‘X’ axis ‘cosine’ component[2].

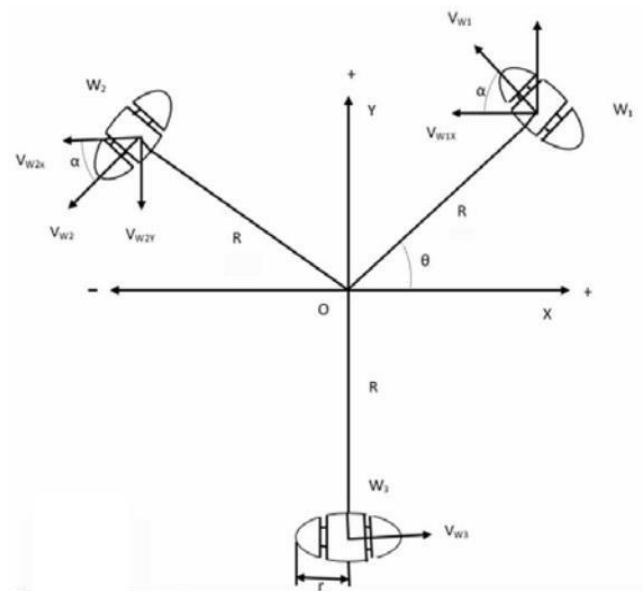

Fig 4. Schematic model of three wheeled omni-directional robot.

For wheel 1 (W1),

$$VW1X = (-) VW1 \cos(\alpha) \dots (1)$$

$$VW1Y = (+) VW1 \sin(\alpha) \dots (2)$$

For wheel 2 (W2),

$$VW2X = (-) VW2 \cos(\alpha) \dots (3)$$

$$VW2Y = (+) VW2 \sin(\alpha) \dots (4)$$

we get,

$$VWX = VW3 - VW1(1/2) - VW2(1/2)$$

$$VWY = VW1(\sqrt{3}/2) - VW2(\sqrt{3}/2)$$

Equation can be written as

$$\begin{bmatrix} VWX \\ VWY \\ V\theta \end{bmatrix} = \begin{bmatrix} -1/2 & -1/2 & 1 \\ \sqrt{3}/2 & -\sqrt{3}/2 & 0 \\ 1/R & 1/R & 1/R \end{bmatrix} \begin{bmatrix} VW1 \\ VW2 \\ VW3 \end{bmatrix}$$

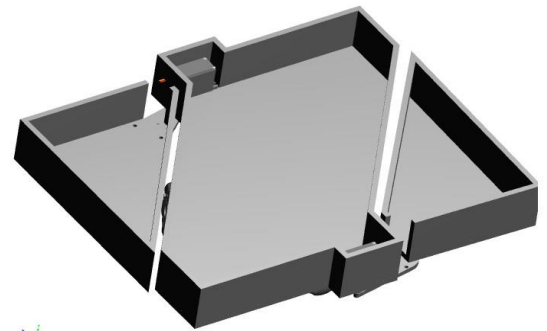

(A)Top View

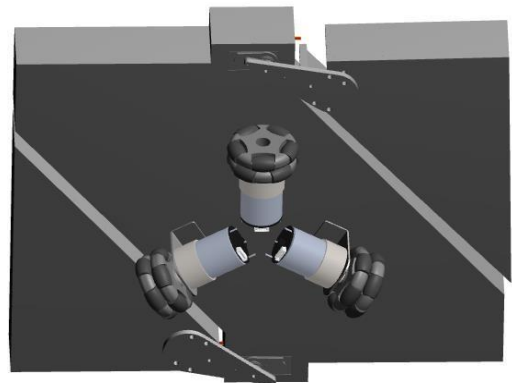

B)bottom View

Fig 5. The 3D CAD Model of Robot

The cad model was developed in solid works The two hinged axes of the robot was rotated in the software to check for blockages during rotation The material used is acrylic with the thickness of 6mm. An arm is attached to the shaft of servo motor .The Arm is connected to the movable part.

VI. NAVIGATION

The ultra-sonic and encoder data will be used to create a map of the floor along with the obstacles. The encoder will provide the current location of the clearer Each encoder that is used in motor will update when the clearer has moved, the amount at which the clearer has moved calculated through software.

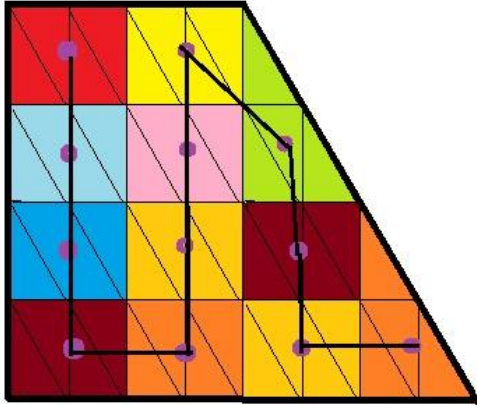

Fig 6. Tiling based path plan

A. Path planning

Once the map is created, the map is fitted by blocks of the cleaner corresponding to the different shapes that are available. This is similar to fitting tiles in a floor, tiling theory is used which divides the map into equally sized right-angle triangles in fig 6. Once completed the software will calculate the different way points these are points are in which the robot has to pass by for cleaning

However, tiling is not possible for some cleaning environments with irregular shapes. For this robot will have to shift between different modes of operation this mode is called behaviour. This is similar to how ants navigate in nature. The main behaviour is to follow the path plan provided by the tiling method. Once an irregular terrain is detected the robot will shift to wall following mode or gap covering mode. After this the robot will follow the original tiling theory. If in case an obstacle is detected in the path of the robot that is not there in the map the robot will move to obstacle avoiding mode.

[3],[8]

B. Gap cleaning mode

In the gap cleaning mode the software will first measure the angle the gap is making. If it is less than 90 degrees the shape of the bot will transform into triangle mode. Then the bot will move until the infrared sensor detects the wall ahead.[4]

C. Pass by mode

If there are any narrow paths in the map that the rectangle shape cannot pass by. Then software will calculate the width of the gap that can fit the slim parallelogram shape.

VII. CONCLUSION

With minimum number of shapes and with each shape offering its own unique cleaning advantage over the other. There is no doubt that this shape configuration will offer one of the best solutions to area coverage. As compared to the other cleaner robots in the industry this robot can easily assess to gaps and take advantage of narrow passages. In this, we presented the robot architecture including of the robot and tiling based path planning techniques for maximum area coverage during cleaning process. Added with multiple benefit free manoeuvrability. Due to the use of three omni wheels the robot can move toward any direction.

Based on the combinatorial properties of the tiling and some derived behaviours which were used for covering any cleaning environment. Based on the design and analysis, we constructed the robot prototype and verified the proposed theorems for area coverage.

REFERENCES

- [1] Rajesh Elara, Ayyalusami Vengadesh And Vinu Sivanantham "Application of Tiling Theory For Path Planning Strategy In A Polyiamond Inspired Reconfigurable Robot" Received November 14, 2018.
- [2] Ranjit Barua, Sajal Mandal and Dr. miran Mandal "Motion Analysis of A Mobile Robot With Three Omni-Directional Wheels" IJSET - International Journal of Innovative Science, Engineering & Technology, Vol. 2 Issue 11, November 2015.
- [3] Prabakaran Veerajagadheswar, Mohan Rajesh Elara, Thejus Pathmakumar, And Vengadesh Ayyalusami "A Tiling-Theoretic Approach to Efficient Area Coverage in a Tetris-Inspired Floor Cleaning Robot" May 30, 2018,
- [4] Joseph I. Jones, Acton, MA (US); Philip R. Mass, Boston, MA (US) Method and system for multi-mode coverage for an autonomous robot Oct. 26, 2004.
- [5] Robot Dynamics. [Http://www.societyofrobots.com/mechanics_dynamics.shtml#acceleration](http://www.societyofrobots.com/mechanics_dynamics.shtml#acceleration)
- [6] V. Prabakaran, M. R. Elara T. Pathmakumar, and S. Nansai, "Floor cleaning robot with reconfigurable mechanism," *Automat. Construction*, vol. 91, pp. 155–165, Jul. 2018.
- [7] V. Prabakaran, R. E. Mohan, V. Sivanantham, T. Pathmakumar, and S. S. Kumar, "Tackling area coverage problems in a reconfigurable floor cleaning robot based on polyomino tiling theory," *Appl. Sci.*, vol. 8, no. 3, p. 342, 2018.
- [8] S. W. Golomb, *Polyominoes—Puzzles, Patterns, Problems, and Packings*. Princeton, NJ, USA: Princeton Univ. Press, 1996.