

Metal Elimination System using PLC

Sumit Thakur
(Author)

Dept. Instrumentation Engineering
Vidyavardhini's College of Engineering and Technology
Mumbai, India

Deepak Joshi
(Author)

Dept. Instrumentation Engineering
Vidyavardhini's College of Engineering and Technology
Mumbai, India

Ashish Tripathi
(Author)

Dept. Instrumentation Engineering
Vidyavardhini's College of Engineering and Technology
Mumbai, India

Omkar Tiwari
(Author)

Dept. Instrumentation Engineering
Vidyavardhini's College of Engineering and Technology
Mumbai, India

Prof. Kanchan Sarmalkar
(Guide)

Dept. Instrumentation Engineering
Vidyavardhini's College of Engineering and Technology
Mumbai, India

Abstract:- Here, we are considering a model of metal detector consisted of one transmitting loop, receiving loop and compensating loop. For distortion of the received signal is associated with the frequency of the transmitting signal through researching of mathematical model, it is feasible to increase the frequency of the detection signal to improve the sensitivity of metal detectors in order to meet food safety requirements. Feasibility of the system has been proved

Keywords:- Food industry, metal detectors, high frequency detecting signals

I. INTRODUCTION

Food safety is an important symbol on the level of national development and quality of life. In the food processing process, there is the inevitable risk of mixed pollutants. When people eat food containing metallic foreign bodies, their oral cavity, esophagus and other digestive system will be hurt. Therefore, detection of metal particles in foods has been an indispensable part of the production in recent past. The past decade has witnessed many directions in the research of metal detectors. Among them, in [1], the basic model analysis was considered. The false alarm problem is proposed [2]. And through the analysis of oscillation circuit model, discipline of circuit parameters variation is invented to deal with different metal magnetism problem [3]. This note is organized as follows. In Section II, we describe the problem formulation of metal detection. Simulation examples and analysis is given in Section

111. Finally, this note is concluded in Section IV.

B. The Theoretical Analysis of Metal Detector Sensor

Equivalent inductance formula of N-turn coil wound closely is given as follows

II. THE PROBLEM FORMULATION OF METAL DETECTION

Metal detector is based on the principle of electromagnetic induction. Commonly the detect circuit of used metal detectors is three-point oscillator circuit [4]. The coil equivalent resistance and equivalent inductance will be changed if metal appears in it. And the increased coil permeability, hysteresis effect and eddy current losses will be partially offset as the metal appears [5]. Thus detection accuracy will be reduced using the method of detecting coil inductance change. Therefore, it is necessary to increase accuracy and sensitivity of the detector and use better discrimination method.

A. Basic Configuration of Metal Detectors

As shown in Figure I, the basic configuration of metal detectors composed of three coils determines the volume of metal objects in food by comparing the received signal with the standard signal.

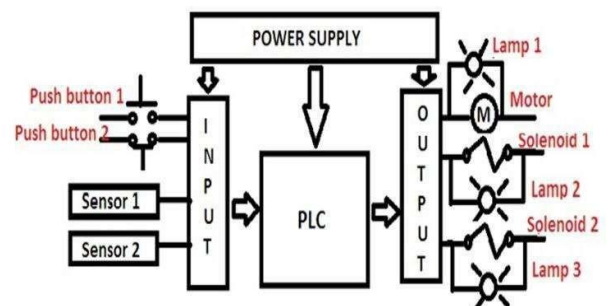

Figure 1. Block Diagram of PLC Interfacing With Metal Detector

$$L = \frac{N\phi}{i} \tag{1}$$

where N is the number of turns, and ϕ is the magnetic flux

magnetic flux of one coil.

The size of the coil magnetic flux can be

calculated by $\phi = BS$, and B can be calculated by

$$B = \frac{\mu i}{D} \tag{2}$$

From (1) and (2) show:

$$L = N \frac{BS}{i} = \frac{\pi}{2} Nr\mu \tag{3}$$

III. TDA0161 PROXIMITY DETECTOR IC WORKING

TDA0161 is a Proximity Detector IC manufactured by STMicroelectronics. It can be used to detect metal objects by detecting the slight changes in the high frequency Eddy current

The TDA0161 IC acts as an oscillator with the help of externally tuned circuit. The changes in supply current will determine the output signal i.e. current is high when a metal object is near and it is low when there is no metal object.

TDA0161 has 8 pins and it comes in Dual in — line Package (DIP). The following image shows the pin diagram of TDA0161

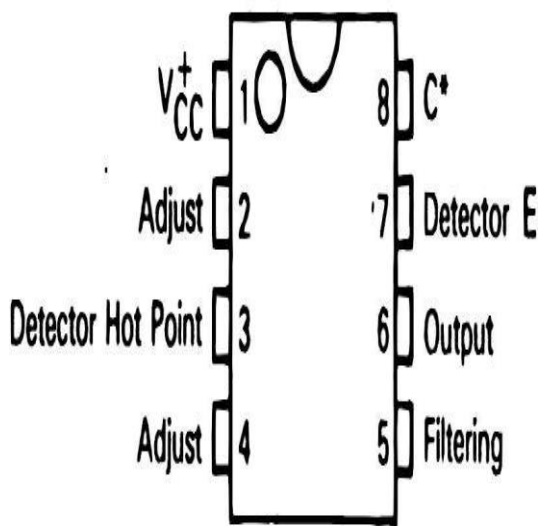

Figure 3.1 Pin Configuration of TDA0161 IC

WORKING OF TDA0161 IC:-

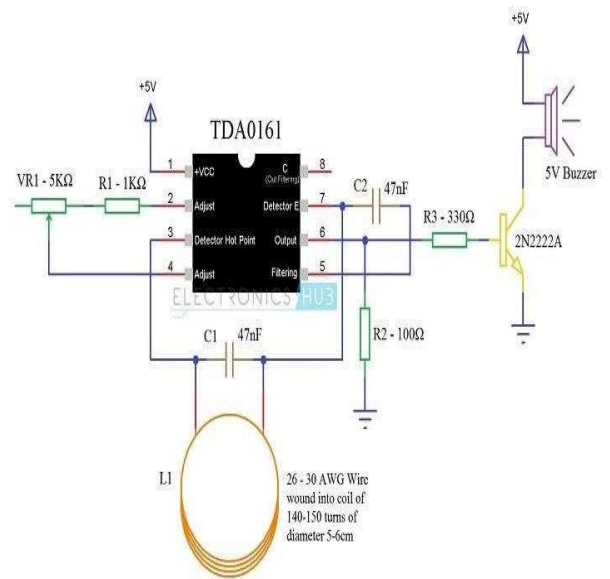

Figure 3.2 Circuit Diagram for the Metal Detector Circuit

- 1) When the LC circuit that is L1 and C1 has got any resonating frequency from any metal which is near to it, electric field will be created which will lead to induces current in the coil and changes in the signal flow through the coil.
- 2) Variable resistor is used to change the proximity sensor value equal to the LC circuit, it is better to check the value when there is coil not near to the metal. When the metal is detected the LC circuit will have changed signal. The changed signal is given to the proximity detector (TDA 0161), which will detect the change in the signal and react accordingly. The output of the proximity sensor will be of 1mA when there is no metal detected and it will be around 10mA when coil is near to the metal
- 3) When the output pin is high the resistor R3 will provide positive voltage to transistor Q1. Q1 will be turned on and led will glow and buzzer will give the **buzz**. Resistor r2 is used to limit the current flow.
- 4) There are three main parts in the metal detector circuit: the LC Circuit, the Proximity Sensor, output LED and the Buzzer. The coil and the capacitor C1, which are connected in parallel, will form the LC circuit.
- 5) Proximity sensor(TDA0161), is triggered by this LC circuit if any metal is detected. The Proximity sensor will then turn on the led and produces alarm using buzzer.
- 6) **LC Circuit:** LC circuit has inductor and capacitor connected in parallel. This circuit starts resonating when there is same frequency material near to it. The LC circuit charges capacitor and inductor alternatively. When the capacitor is

charged fully ,charge is applied to inductor.

7) Inductor starts charging and when charge across the capacitor is nil, it draws charge from the inductor in reverse polarity. Then inductor charge is reduced and again the process repeats.Note inductor is a magnetic field storage device and capacitor is electric field storage device.

8) **Proximity Sensor:** The proximity sensor can detect the objects with out any physical interference. The proximity sensor will work same as infrared sensor, proximity also release a signal, it will not give output unless and until there is no change in the reflected back signal.

9) If there is a change in signal it will detect and give the output accordingly. There are different proximity sensors for example to detect plastic material we can use capacitive type proximity and for metals we should use inductive type.

10) The LC Circuit, which consists of L1 (coil) and C1, is the main metal detector part of the circuit. With the help of this LC Circuit, which is also called as Tank Circuit or Tuned Circuit, the TDA0161 IC acts as an oscillator and oscillates at a particular frequency.

11) When the LC circuit detects any resonating frequency from any metal which is near to it, electric field will be created which will lead to induces current in the coil and changes in the signal flow through the coil.

12) Variable resistor is used to change the proximity sensor value equal to the LC circuit, it is better to check the value when the coil is not near any metal object. When the metal is detected, the LC circuit will have changed signal.

13) The changed signal is given to the proximity detector (TDA 0161), which will detect the change in the signal and react accordingly. The output of the proximity sensor will less than 1mA when there is no metal detected and it will be around 10mA (usually greater than 8mA) when coil is near to the metal.When the output pin is high, the resistor R3 will provide positive voltage to transistor Q1. Q1 will be turned on and LED will glow (not shown in the circuit) and buzzer will be activated.

IV.HOW DO METAL DETECTORS WORK??

Metal detectors for food primarily are used for the purpose of consumer protection. Despite maximum care metallic contaminations of food products during the production process cannot be fully excluded. Metal particles that enter the product during the production process or already are contained in the raw material may cause serious injuries of consumers. The consequences for the producing company are numerous and serious and include compensation claims and expensive recalls. Even bigger and longer-lasting damage is caused by the negative brand image and the

loss of consumer trust caused by impure food products.

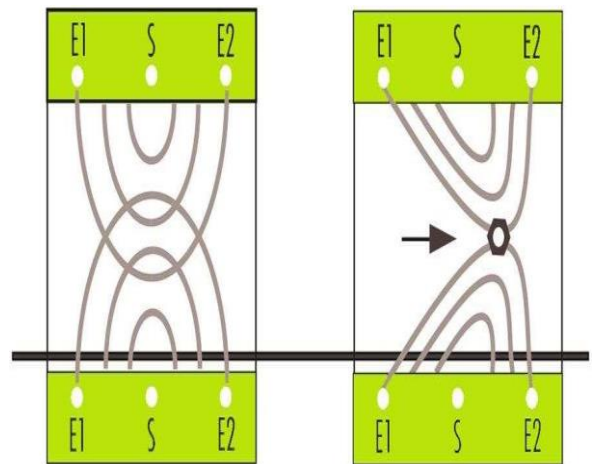

Figure 4. Metal Detector Working

Basically there are several types of metal detectors that operate with different detection methods. In the food industry, metal detectors usually apply the transmitter-receiver method .

Such metal detectors are equipped with a transmitter coil and two receiver coils. The transmitter coil generates a constant electromagnetic field. When a metal particle passes the detector it interferes with the electromagnetic field, causing a signal to be detected by the receiver coils. The electronic unit in the metal detector analyses this signal, evaluates it and signals a metal contamination. As a rule metal detectors in the food industry are equipped with automatic reject units that directly separate the contaminated product from the production line.

J.TYPES OF CONTAMINANTS

Metal	Example	Detection
Ferrous	Iron	Easy
Non-ferrous	Copper, lead	Relatively easy
Stainless Steel	304L (EN58E) grade	Relatively difficult

Ferrous contamination is both magnetic and a good electrical conductor, **and** therefore **is easily** detected. Most metal detectors are able to detect small ferrous particles.

Non-ferrous metals such as aluminum, copper and lead are non-magnetic but are good electrical conductors. They are generally quite easy to detect.

Stainless steel comes in many different grades, some magnetic and totally non-magnetic. Their conductivity varies depending on the grade

VI. SOFTWARE OVERVIEW

WECON PLC Editor Software Overview

PLC is a Micro Computer used for the Automation of typical industrial electromechanical processes. PLCs are widely used in various types of machines of many industries.

It reads external input signals such as: the state of buttons, sensors, switches and pulse waves, and then uses a microprocessor to perform logic, sequence, timing, counting and arithmetic operations, resulting in the corresponding output signal based on the input signal status or internally stored value and pre-written program.

WECON PLC editor uses ladder and instructions list as programming language.

Ladder

Ladder logic is widely used to program PLCs, where sequential control of a process or manufacturing operation is required.

Ladder logic is useful for simple but critical control systems or for reworking old hardwired relay circuits. As programmable logic controllers became more sophisticated it has also been used in very complex automation systems. It is a graphic language evolution came in relay ladder original relay control system based on the devices used in the design, such as buttons Frequency,"Chinese Journal of Scientific Instrument, vol.27, 2006,

X, intermediate relay M, time relay T, counter C, and so on pp. 76-9

similar properties contact time of electrical device. The ladder as below figure shows.

Instructions list

Instruction List (IL) is designed for programmable logic controllers (PLCs). It is a low level language and resembles assembly. All instructions and operands are inputted for PLC programming. The IL has been shown in the below figure.

Program switch

According to their own programming practice, users can switch ladder and instruction list in order to improve programming efficiency. There is a "Switch" function as below figure shows.

VI. CONCLUSION

In this part, we consider metal detection technology of food industry. Metal detection technology is based on the principle of electromagnetic induction. A metal detector is consisted of one transmitting loop, receiving loop and compensating loop and used to detect harmful metal particles in the food in a production line. It is necessary to increase the frequency of the detection signal to improve the sensitivity of metal detectors in order to meet food safety requirements. Metal detection technology is based on the principle of electromagnetic induction. A metal detector consists of one transmitting loop and one receiving loop and is used to detect harmful metal particles in the food packets present on the production line. It is necessary to increase the frequency of the detection signal to improve the sensitivity of metal detectors in order to meet food safety standards. Elimination of the contaminated packets is very necessary in order to maintain quality standards and to avoid product recalls. Metal elimination system or product sorting based on metal detection hence becomes one of the most important aspects of a Food Packaging industry.

REFERENCES

- [1] Sadao Yamazaki, Hiroshi Nakane, "Basic Analysis of a Metal Detector," IEEE Transactions On Instrumentation And Measurement, ol.51, No.4, Aug. 2002, pp.SIO- SI4, doi:10.1109/TIM.2002.S03397.
- [2] H.Krueger, "Advanced Signal Processing for Reduction of False Alarm Rate of Metal Detectors for Humanitarian Mine Clearance," H,Krueger, IMTC2006 Instrumentation and Measurement Technology Conference, Sorrento, Italy 24-27 April 2006, pp.145-2 1456.
- [5] Pang Ruifan, "Research on Dual Frequency Metal Detector," Journal of PLA University Science and Technology (Natural Science), vol. 2, 2001, pp.1-5.
- [6] I. T. McMichael, E. C. Nallon, V. P. Schnee, W. R. Scott, and M. S. Mirotznik, "EBG antenna for GPR collocated with a metal detector for landmine detection," IEEE Geoscience and Remote Sensing Letters, vol. 10, no. 6, pp. 1329-1333, 2013. View at: Publisher Site | Google Scholar
- [7] M. S. Sharawi and M. I. Sharawi, "Design and implementation of a low cost VLF metal detector with metal-type discrimination capabilities," in Proceedings of the IEEE International Conference on Signal Processing and Communications (ICSPC '07), pp. 480-483, November 2007. View at: Publisher Site | Google Scholar
- [8] T. Miyakawa and K. Honjo, "Development of instrument detecting nonmetal foreign bodies in food material," IEEE Transactions on Instrumentation and Measurement, vol. 43, no. 2, pp. 359-363, 1994. View at: Publisher Site | Google Scholar
- [9] M. Zourob, S. Mohr, and N. J. Goddard, "Integrated deep-probe optical waveguides for label free bacterial detection," in Proceedings of the International Symposium on Signals, Systems and Electronics (ISSSE '07), pp. 49-52, Montreal, Canada, August 2007. View at: Publisher Site | Google Scholar
- [10] B. Liu and W. Zhou, "The research of metal detectors using in food industry," in Proceedings of the International Conference on Electronics and Optoelectronics (ICEOE '11), vol. 4, pp. V4-43-

- V4-45, Dalian, China, July 2011.
View at: [Publisher Site](#) | [Google Scholar](#)
- [11] J. Kwon, J. Lee, and W. Kim, "Real-time detection of foreign objects using x-ray imaging for dry food manufacturing line," in Proceedings of the 12th IEEE International Symposium on Consumer Electronics (ISCE '08), pp. 1–4, April 2008.
View at: [Publisher Site](#) | [Google Scholar](#)
- [12] W. S. Hua, J. R. Hooks, W. J. Wu, and W. C. Wang, "Development of a polymer based fiberoptic magnetostrictive metal detector system," in Proceedings of the International Symposium on Optomechatronic Technologies (ISOT '10), pp. 1-5, Toronto, Canada, October 2010.
View at: [Publisher Site](#) | [Google Scholar](#)
- [3] V Pugatch, "Micro strip Metal Detector for the Beam 1, pp. 474–477, May 2001.
View at: [Google Scholar](#)
- Monitoring," Nuclear Instruments & Methods in Physics Research A, vol.551,2007, pp.531-534, doi: 10.1016/j.nima.2007.05.042.
- [4] Liu Huijuan, "Metal Detection Method Based on Voltage and
- [13] T. Nagaishi, F. Kamitani, H. Ota et al., "First practical high Tc SQUID system for the detection of magnetic contaminants in commercial products," IEEE Transactions on Applied Superconductivity, vol. 17, no. 2, pp. 800–803, 2007.
View at: [Publisher Site](#) | [Google Scholar](#)
- [14] H. Krause, G. I. Panaitov, N. Wolters et al., "Detection of magnetic contaminations in industrial products using HTS SQUIDs," IEEE Transactions on Applied Superconductivity, vol. 15, no. 2, pp. 729-732, 2005.
View at: [Publisher Site](#) | [Google Scholar](#)
- [15] S. Yamazaki, H. Nakane, and A. Tanaka, "Basic analysis of a metal detector," in Proceedings of the 18th IEEE Instrumentation and Measurement Technology Conference, vol.
- [16] S. Yamazaki, H. Nakane, and A. Tanaka, "Basic analysis of a metal detector," IEEE Transactions on Instrumentation and Measurement, vol. 51, no. 4, pp. 810–814, 2002.
View at: [Publisher Site](#) | [Google Scholar](#)
- [17] P. P. Silvester and D. Omeragic, "Sensitivity of metal detectors to spheroidal targets," IEEE Transactions on Geoscience and Remote Sensing, vol. 33, no. 6, pp. 1331–1335,

View at: [Publisher Site](#) | [Google Scholar](#)
- [18] Z. Tang and L. Carter, "Metal detector head analysis," in Proceedings of the 5th International Conference on Sensing Technology, pp. 93–96, Palmerston North, New Zealand, 2011.
View at: [Google Scholar](#)
- [19] K. R. Blay, F. Weiss, D. A. Clark, G. J. J. B. de Groot, M. Bick, and D. Sen, "Signal processing techniques for improved performance of a SQUID-based metal-detector," IEEE Transactions on Applied Superconductivity, vol. 19, no. 3, part 1, pp. 812–815, 2009.
View at: [Publisher Site](#) | [Google Scholar](#)
- [20] M. Herrmann and K. Sakai, "Objects in powders detected and imaged with THz radiation," in Proceedings of the IEEE Conference on Lasers and Electro-Optics (CLEO '00), San Francisco, Calif, USA, May 2000.
View at: [Publisher Site](#) | [Google Scholar](#)
- [21] M. Brighton and M. J. English, "Calculation of optimum spacing for a three coil axially symmetric metal detector," Electronics Letters, vol. 29, no. 10, pp. 838–839, 1993.
View at: [Publisher Site](#) | [Google Scholar](#)
- [22] P. P. Silvester and D. Omeragic, "Sensitivity maps for metal detector design," IEEE Transactions on Geoscience and Remote Sensing, vol. 34, no. 3, pp. 788–792, 1996.
View at: [Publisher Site](#) | [Google Scholar](#)